

## Frucosol PF-300 Potato Peeler Diagram

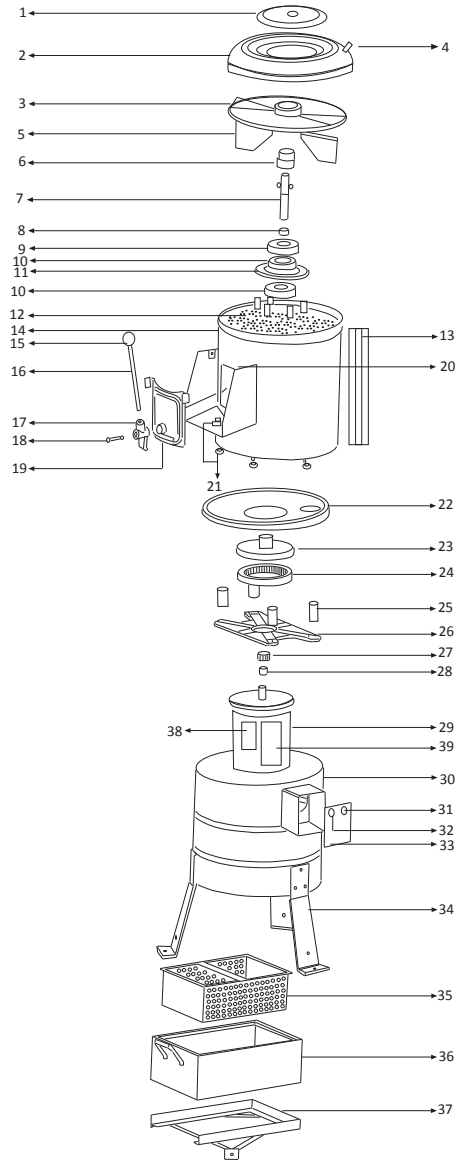

[info@frucosol.uk.com](mailto:info@frucosol.uk.com)  
[www.frucosol.uk.com](http://www.frucosol.uk.com)



## Frucosol PF-300 Potato Peeler Diagram

REF	NO	Frucosol PF-300 Potato Peeler Diagram	Price
pf300-001	1	Upper cover	POA
pf300-002	2	Dome	POA
pf300-003	3	Turning plate	POA
pf300-004	4	Rubber entry	POA
pf300-005	5	Fan	POA
pf300-006	6	Nut A	POA
pf300-007	7	Shaft	£92.00
pf300-008	8	Nut B	£20.00
pf300-009	9	Rubber locak	£72.00
pf300-010	10	Bearing	£72.00
pf300-011	11	Ring	£72.00
pf300-012	12	Abrasive cloth	£50.00
pf300-013	13	Steel sand stick	£24.00
pf300-014	14	Upper chamber	POA
pf300-015	15	Handle ball	POA
pf300-016	16	Handle ball	POA
pf300-017	17	Handle seat	POA
pf300-018	18	Screw	POA
pf300-019	19	Exit of door	POA
pf300-020	20	Rubber of door	£24.00
pf300-021	21	Joint	POA
pf300-022	22	Seat	POA
pf300-023	23	Ring plate	£120.00
pf300-024	24	Internal gear	£150.00
pf300-025	25	Nut C	POA
pf300-026	26	Motor joint	POA
pf300-027	27	Gear	POA
pf300-028	28	Nut D	POA
pf300-029	29	Motor	£750.00
pf300-030	30	Lower chamber	POA
pf300-031	31	Contactora	POA
pf300-032	32	Green switch	POA
pf300-033	33	Red switch	POA
pf300-034	34	Machine support	POA
pf300-035	35	Filter tray	POA
pf300-036	36	Water tray	POA
pf300-037	37	Water tray arm	POA
pf300-038	38	Capacitor 20mf	£40.00
pf300-039	39	Capacitor 25mf	£24.00

Prices Plus VAT & Delivery

